

Foreword

The formulation of this national standard was initiated by the Agricultural Machinery Testing and Evaluation Center (AMTEC) under the project entitled “Enhancing the Implementation of the AFMA Through Improved Agricultural Engineering Standards” which was funded by the Bureau of Agricultural Research (BAR) of the Department of Agriculture (DA).

This standard has been technically prepared in accordance with PNS 01-4:1998 (ISO/IEC Directives Part 3:1997 – Rules for the Structure and Drafting of International Standards. It specifies the general requirements for layer housing.

The word “shall” is used to indicate requirements strictly to be followed in order to conform to the standard and from which no deviation is permitted.

The word “should” is used to indicate that among several possibilities one is recommended as particularly suitable, without mentioning or excluding others, or that a certain course of action is preferred but not necessarily required.

In the formulation of this standard reference were made to:

Animal Husbandry and Agricultural Journal. Poultry Raising, Know the tips. August, 1993.

Barre, H. J. and L. L. Sammet. Farm Structures. John Wiley and Sons, 1950.

Batty, J. and Mrs. M. Batty. Poultry Houses and Appliances. Spur Publications Company, 1976

Card, L. E. and M. C. Nesheim, Poultry Production. LEA and FEBIGER, Philadelphia, 11th edition..

Dougherty, J. E. and H. L. Belton. Poultry Houses and Equipment, Buletin # 476, University of California, Agricultural Experiment Station. 1940.

Esmay, M. L. and Dixon, John E. Environmental Control for Agricultural Buildings.

HSUS Recommended Humane Standards for raising Livestock and Poultry.

North, M. O. and D. D. Bell. Commercial Chicken Production Manual. Chapman and Hall, New York. 4th edition, 1990.

PCARRD, Philippine Recommends for Broiler Production.

Price, C. J. and J. E. Reed. Poultry Husbandry II, Notes for Students of Animal Husbandry, UNDP – FAO, 1971.

Agricultural Structures – Housing for Layer Production

1 Scope

This standard specifies the minimum requirement for layer production. It includes space requirement, feeding and watering facilities.

2 Reference

The following normative document contains provisions which through reference in this text constitute provisions of this National Standard:

Philippine Electrical Code 2000

PAES 414-1:2002 Agricultural Structures – Waste Management Structures: Part 1 –
Agricultural Liquid Waste

PAES 414-2:2002 Agricultural Structures – Waste Management Structures: Part 2 –
Agricultural Solid Waste - Composting

3 Definitions

For the purpose of this standard, the following definitions shall apply:

3.1**litter**

material used as bedding for animals

3.2**litter type**

type of flooring utilizing the most commonly available materials such as rice hull and rice straw and wood shavings over the cemented floor

3.3**slotted type**

type of flooring with openings to facilitate cleaning of the droppings

3.4**slot-litter type**

combination of slotted and litter type flooring wherein slats cover 60% of the total floor area and 40% is covered with litter.

3.5**community nest**

large nesting boxes for 3 - 6 layers

4 Location

4.1 The location shall conform to the land use plan of the area.

4.2 The site shall be accessible to service roads, water supply and electric lines.

4.3 The site shall be well drained and allows for free air circulation.

4.4 The building shall be constructed in an east-west orientation and the structure for marketable animals shall be located near the service road.

4.5 The site shall be located where the prevailing winds will not carry odors to the farmhouse.

5 Classification

5.1 Type of confinement

5.1.1 pen (floor production)

5.1.2 cage (cage layer production)

5.2 Type of flooring

5.2.1 litter type

5.2.2 slotted type

5.2.3 slot-litter type

6 Space requirement**6.1 Pen type**

Table 1 shows the minimum requirements for various floor systems for pen type housing.

Table 1 – Floor space requirements for layers in pen type housing

Stage	Space requirements m²/100 birds
Growing (7 – 22 weeks)	
Litter floor	14
Slotted floor	6
Slot-litter floor	7
Laying (beyond 22 weeks)	
Litter floor	17
Slotted floor	9
Slot-litter floor	14

6.2 Cage type

The minimum space requirement for birds in cages shall be 5m²/100 birds.

7 Structural requirement

7.1 Roof

7.1.1 Roofing material should be made of corrugated G.I. sheets and other durable roofing materials. At least one-meter roof overhang shall be provided to ensure shade and to protect the birds from rain.

7.1.2 Roof should be equipped with gutters so that rainwater can be drained away separately.

7.2 Ceiling (optional)

Ceiling height shall be at least 2.4 m high.

7.3 Walls

7.3.1 The walls should be made of suitable materials such as chicken wire or bamboo slats.

7.3.2 There should be provision to protect young chicks and older birds during periods of cold weather and extreme winds.

7.4 Doors

7.4.1 Entrance doors shall be at least 900 mm wide by 2 m high and shall be made to swing inward. It shall be covered with 25 mm mesh wire netting.

7.4.2 Doors between pens shall be hung in pairs and be made to swing in both direction so that feed and litter carriers can be pushed through from either direction.

7.5 Floors

7.5.1 Slotted floor

7.5.1.1 The width of the slat shall be 25 mm - 50 mm and the space in between slats shall be 25 mm – 38 mm. On top of the slats, plastic net or fish net with 25 mm holes shall be used.

7.5.1.2 If welded wire is used. It should have 625 mm² mesh. The wire shall be supported every 300 mm.

7.5.1.3 Slats or wire floors shall be constructed in sections so that they may be removed when it is necessary to clean the droppings from under them, or when the house is cleaned.

7.5.1.4 The floor shall be elevated at least 900 mm from the ground and the posts should have a diameter of at least 200 mm.

7.5.2 Litter-type floor

7.5.2.1 Litter material shall be at least 50 mm - 100 mm deep over the cemented floor. Around the cemented floor, there should be solid wall with a height of 600 mm to retain the litter.

7.5.2.2 The litter material shall be:

- light in weight
- have a medium particle size
- highly absorbent
- dry rapidly
- soft and compressible
- low thermal conductivity
- inexpensive

8 Functional requirement

8.1 Pen sizes

8.1.1 Width of the pen shall be about 10 m - 12 m.

8.1.2 The length of the house shall depend on the terrain of the land and on the length of the automatic feeding equipment.

8.2 Laying Cage

8.2.1 The cage should be designed with wire floor and sidewall (Figure 1). The distance spacing between the wires in front of the cage shall be 60 mm to allow feeding.

8.2.2 Cages should have similar height but the size of the floor shall vary according to the size of the chicken and number of birds per cage.

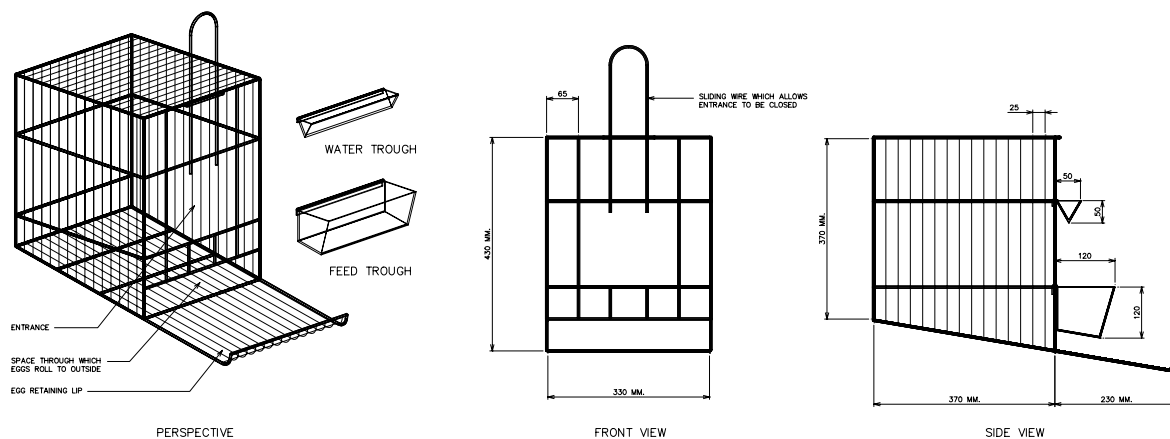

Figure 1 – Typical design of a laying cage

8.2.3 Floor shall be made of 12 gauge wire and should have a slope of 21% - 25%. The dimension of the slot should be 25 mm – 40mm x 60 mm.

8.2.4 Dropping tray shall be provided underneath the floor of the cage.

8.3 Nest (optional)

8.3.1 Nests shall be adequate in size, ample, easily cleaned and well ventilated. Nests are not needed if layers are confined in cages. However, provide nest if layers are kept on litter floor, slat floor, or slat-litter floor pens.

8.3.2 Nest should be either individual or community nest (Figure 2):

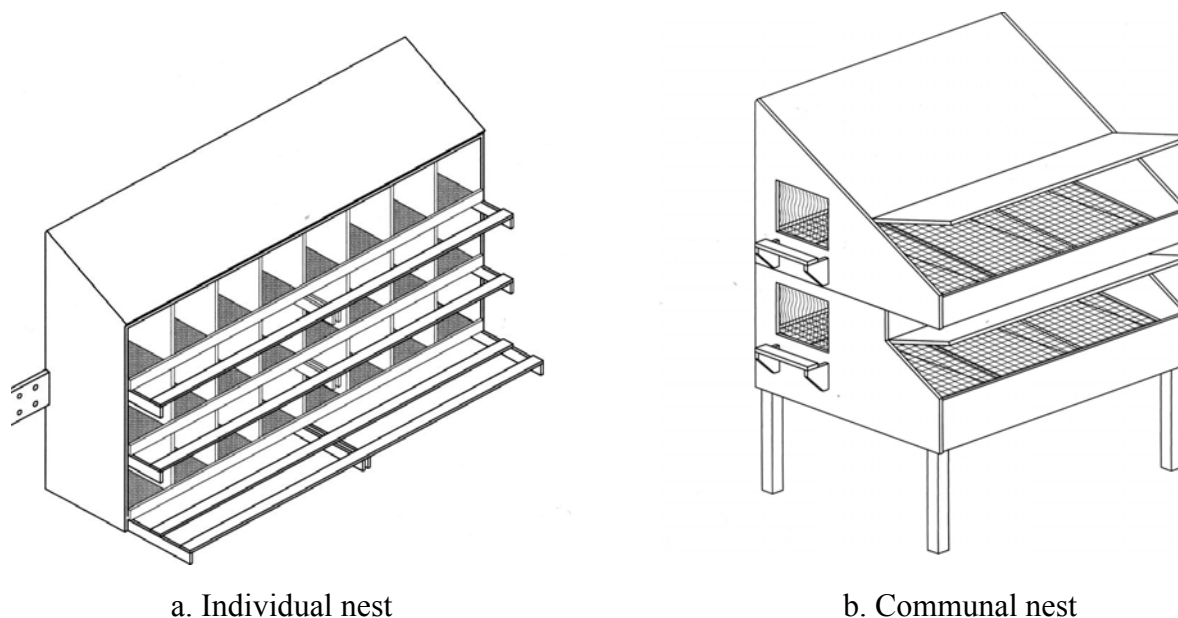

a. Individual nest

b. Communal nest

Figure 2 – Types of nest

8.3.2.1 Individual nests (Figure 2a): Individual nest shall be 310 mm wide, 310 mm high and 310 mm - 360 mm long. The nest should be constructed with wire mesh at the back or with

the back open for adequate air movement. The bottom of the nests shall be removable for easy cleaning. There shall be one nest for each 5 to 6 layer.

8.3.2.2 Community nest(Figure 2b): These are unpartitioned boxes about 600 mm wide and 2.4 m long, with 200 mm opening at each end through which the layers enter and leave. Each shall have a sloping cover that is hinged so that it may be opened. The nest should be constructed with wire mesh at the back or with the back open for adequate air movement. The laying floor should be removable and should be made of 13 mm galvanized wire mesh. The laying floor shall be sloping 7% towards the other side, which is provided with foam rubber bumper pad. One nest box should be provided for 20 – 25 layers.

8.4 Aisles and Walkways

Where carts are used for feeding and egg gathering, provide a clear passage of 800 mm between cage rows and to the longitudinal walls. At the end walls, 2.4 m clear passage shall be provided.

8.5 Equipment and Facilities

8.5.1 Feeders

8.5.1.1 The recommended space requirement for feeder shall be 65 mm/bird.

8.5.1.2 Each feeding trough should have a guard or lip about 10 mm - 20 mm to prevent the feed from being scratched out or beaked out onto the floor. It should be provided with wire bars or grills to prevent scratching and billing (Figure 3).

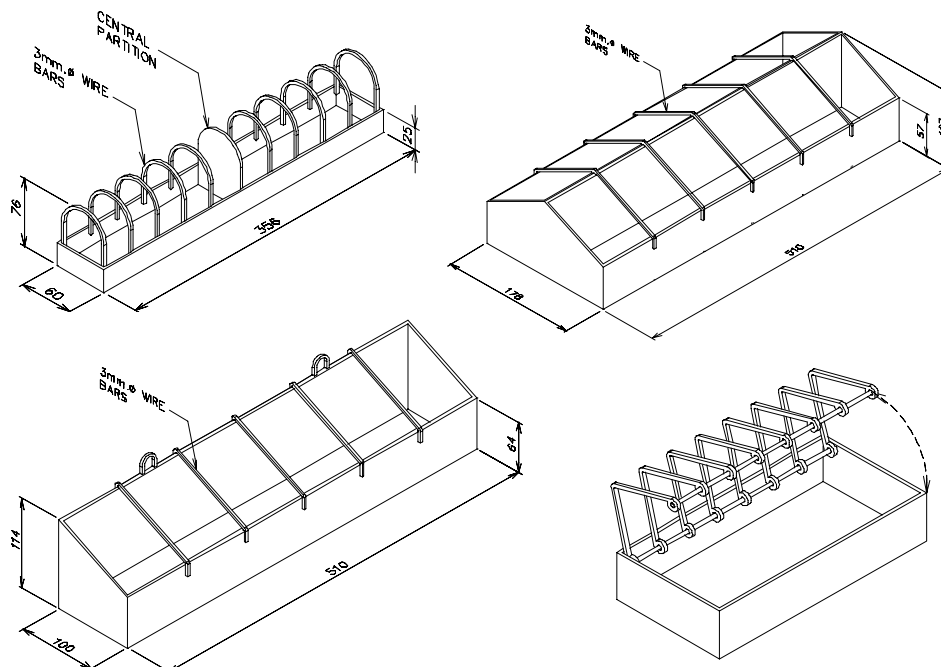

Figure 3 – Typical design of feed trough

8.5.1.3 Round feeders should be provided with adjustable slots to control feed flow (Figure 4). Edges of feeder pan should be rolled for safety.

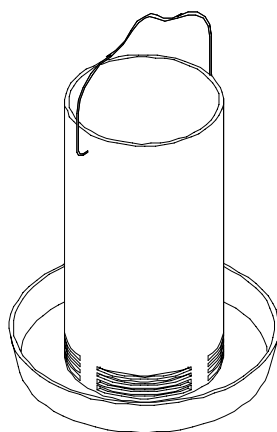

Figure 4 - Typical design of round feeder

8.5.1.4 As the flock grows, the feeding system shall be raised to maintain the feed level at the same height as the back of the chickens.

8.5.2 Waterer

8.5.2.1 The recommended space requirement for waterers shall be 20 mm/bird.

8.5.2.2 Waterers or watering systems should either be one of the following: automatic trough with either suspension valve, float valve or electric valve; hanging waterers; and cup waterers.

8.5.2.3 Waterers shall be spaced uniformly throughout the house; no bird shall have to go over 3 m to get water.

8.5.2.4 To facilitate cleaning, the shape and size of the waterers should be semi-circular and fairly wide and supported by an adjustable bracket to permit easier adjustment. It should have a removable stopper at the drainage end to allow easier cleaning.

8.6 Lighting

Artificial lighting with an intensity of 200 lux (refer Annex B) shall always be available for use during the night or darkened periods of the day. All electrical design and installation shall conform to Philippine Electrical Code.

8.7 Ventilation

8.7.1 Natural ventilation

8.7.1.1 Outlets should be either ridge or chimney opening on the downwind side of the building. It should be preferably located at the highest point in a building.

8.7.1.2 Inlets should be through vent doors, curtains or other large openings along the long sides of the building.

8.7.1.3 If necessary, automatic controls should be provided to maintain the indoor temperature and provide air exchange as weather changes hourly and seasonally. Natural ventilation system controllers should be available to regulate air exchange by adjusting inlet and outlet opening sizes. Various devices should be used to adjust the opening size: pneumatic systems; either manual or motorized cable and winch systems; and motorized mechanical arms.

8.7.2 Mechanical ventilation (if necessary)

Fans should be installed on the side opposite to the prevailing winds.

9 Waste disposal

For waste management, refer to **PAES 414-1:2002** and **PAES 414-2:2002**.

ANNEX A
(informative)

Different Types of Cage Arrangement



A
Single Deck
Front Waterer

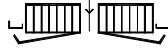

B
Single Deck
Back Waterer



C
Single Deck
Automatic Egg Pickup



D
Flat Deck
Automatic Egg Pickup



E
Double Deck
Stair Step

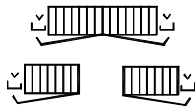

F
Double Deck
Offset

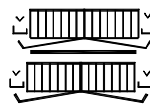

G
Double Deck
Vertical

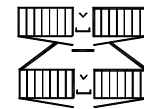

H
Vertical Double Deck
Automatic Egg Pickup

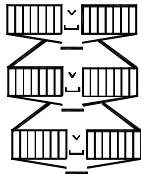

I
Vertical Triple Deck
Automatic Egg Pickup

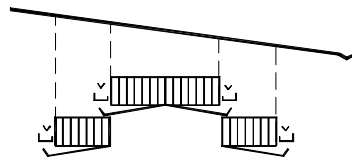

J
Stair Step
Sawtooth Roof

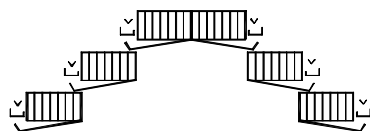
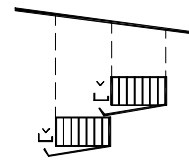

K
Triple Deck
Stair Step

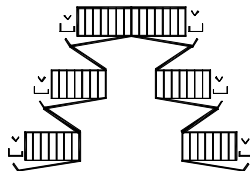

L
Triple Deck
Offset

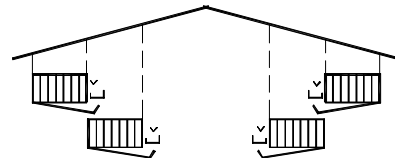

M
Stair Step
Open-Sided

Annex B
(informative)

Lighting Requirements

Lighting Intensity lux	No. of Bulbs Required per m ²							
	Incandescent lamp						Fluorescent lamp	
	25W	40W	60W	100W	150W	200W	20W	40W
500	3.935	1.989	1.052	0.520	0.314	0.226	0.682	0.266
400	3.148	1.591	0.842	0.416	0.251	0.181	0.546	0.213
300	2.361	1.193	0.631	0.312	0.189	0.136	0.409	0.160
200	1.574	0.796	0.421	0.208	0.126	0.090	0.273	0.107
150	1.180	0.597	0.316	0.156	0.094	0.068	0.205	0.080
100	0.787	0.398	0.210	0.104	0.063	0.045	0.136	0.053
50	0.393	0.199	0.105	0.052	0.031	0.023	0.068	0.027
10	0.079	0.040	0.021	0.010	0.006	0.005	0.014	0.005